

SOCKET HEAD CAP SCREWS (1960 Series)

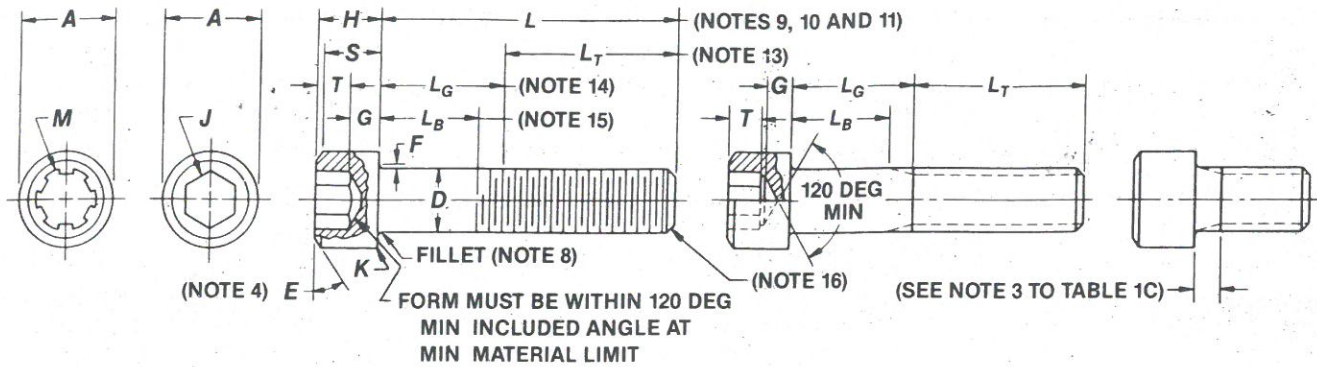

Table 1A Dimensions of Hexagon and Spline Socket Head Cap Screws (1960 Series)

Nominal Size or Basic Screw Diameter	D		A		H		S	M	J	T	G	K	
	Body Diameter		Head Diameter		Head Height		Head Side Height	Spline Socket Size	Hexagon Socket Size	Key Engagement	Wall Thickness	Chamfer or Radius	
	Max	Min	Max	Min	Max	Min	Min	Nom	Nom	Min	Min	Max	
0	0.0600	0.0600	0.0568	0.096	0.091	0.060	0.057	0.054	0.060	0.050	0.025	0.020	0.003
1	0.0730	0.0730	0.0695	0.118	0.112	0.073	0.070	0.066	0.072	0.062	0.031	0.025	0.003
2	0.0860	0.0860	0.0822	0.140	0.134	0.086	0.083	0.077	0.096	0.078	0.038	0.029	0.003
3	0.0990	0.0990	0.0949	0.161	0.154	0.099	0.095	0.089	0.096	0.078	0.044	0.034	0.003
4	0.1120	0.1120	0.1075	0.183	0.176	0.112	0.108	0.101	0.111	0.094	0.051	0.038	0.005
5	0.1250	0.1250	0.1202	0.205	0.198	0.125	0.121	0.112	0.111	0.094	0.057	0.043	0.005
6	0.1380	0.1380	0.1329	0.226	0.218	0.138	0.134	0.124	0.133	0.109	0.064	0.047	0.005
8	0.1640	0.1640	0.1585	0.270	0.262	0.164	0.159	0.148	0.168	0.141	0.077	0.056	0.005
10	0.1900	0.1900	0.1840	0.312	0.303	0.190	0.185	0.171	0.183	0.156	0.090	0.065	0.005
1/4	0.2500	0.2500	0.2435	0.375	0.365	0.250	0.244	0.225	0.216	0.188	0.120	0.095	0.008
5/16	0.3125	0.3125	0.3053	0.469	0.457	0.312	0.306	0.281	0.291	0.250	0.151	0.119	0.008
3/8	0.3750	0.3750	0.3678	0.562	0.550	0.375	0.368	0.337	0.372	0.312	0.182	0.143	0.008
7/16	0.4375	0.4375	0.4294	0.656	0.642	0.438	0.430	0.394	0.454	0.375	0.213	0.166	0.010
1/2	0.5000	0.5000	0.4919	0.750	0.735	0.500	0.492	0.450	0.454	0.375	0.245	0.190	0.010
5/8	0.6250	0.6250	0.6163	0.938	0.921	0.625	0.616	0.562	0.595	0.500	0.307	0.238	0.010
3/4	0.7500	0.7500	0.7406	1.125	1.107	0.750	0.740	0.675	0.620	0.625	0.370	0.285	0.010
7/8	0.8750	0.8750	0.8647	1.312	1.293	0.875	0.864	0.787	0.698	0.750	0.432	0.333	0.015
1	1.0000	1.0000	0.9886	1.500	1.479	1.000	0.988	0.900	0.790	0.750	0.495	0.380	0.015
1 1/8	1.1250	1.1250	1.1086	1.688	1.665	1.125	1.111	1.012	...	0.875	0.557	0.428	0.015
1 1/4	1.2500	1.2500	1.2336	1.875	1.852	1.250	1.236	1.125	...	0.875	0.620	0.475	0.015
1 3/8	1.3750	1.3750	1.3568	2.062	2.038	1.375	1.360	1.237	...	1.000	0.682	0.523	0.015
1 1/2	1.5000	1.5000	1.4818	2.250	2.224	1.500	1.485	1.350	...	1.000	0.745	0.570	0.015
1 3/4	1.7500	1.7500	1.7295	2.625	2.597	1.750	1.734	1.575	...	1 1/4	0.870	0.665	0.015
2	2.0000	2.0000	1.9780	3.000	2.970	2.000	1.983	1.800	...	1 1/2	0.995	0.760	0.015
2 1/4	2.2500	2.2500	2.2280	3.375	3.344	2.250	2.232	2.025	...	1 3/4	1.120	0.855	0.031
2 1/2	2.5000	2.5000	2.4762	3.750	3.717	2.500	2.481	2.250	...	1 3/4	1.245	0.950	0.031
2 3/4	2.7500	2.7500	2.7262	4.125	4.090	2.750	2.730	2.475	...	2	1.370	1.045	0.031
3	3.0000	3.0000	2.9762	4.500	4.464	3.000	2.979	2.700	...	2 1/4	1.495	1.140	0.031
3 1/4	3.2500	3.2500	3.2262	4.875	4.837	3.250	3.228	2.925	...	2 1/4	1.620	1.235	0.031
3 1/2	3.5000	3.5000	3.4762	5.250	5.211	3.500	3.478	3.150	...	2 3/4	1.745	1.330	0.031
3 3/4	3.7500	3.7500	3.7262	5.625	5.584	3.750	3.727	3.375	...	2 3/4	1.870	1.425	0.031
4	4.0000	4.0000	3.9762	6.000	5.958	4.000	3.976	3.600	...	3	1.995	1.520	0.031
See Notes 1, 2, 3	2, 15		3				4		20	21			6

NOTES:

1. Nominal Size. Where specifying nominal size in decimals, zeros preceding decimal and in the fourth decimal place shall be omitted.

2. Body. The term *body* refers to the unthreaded cylindrical portion of the shank for those screws not threaded to the head.
3. Head Diameter. Heads may be plain or knurled at the option of the manufacturer, unless specified

